



Equipped with AEM® Dryflow™ Filter
No Oil Required!

INSTALLATION INSTRUCTIONS

PART NUMBER: 21-400

1988-1991	HONDA	Civic	L4-1.6L	C.A.R.B. E.O. # D-670
1988-1991	HONDA	CRX	L4-1.6L	C.A.R.B. E.O. # D-670

* **NOTE:** Legal in California only for racing vehicles which may never be used upon a highway

PARTS LIST

Description	Qty.	Part Number
Element Parts Kit 2.50 X 5" Dry Ele.	1	21-201DK
Inlet Pipe	1	2-535
Hose; 5/16ID X 16"L	1	5-2016
Hose, Silicone 2.50x3" Blk.	1	5-250
Hose; 1/2"ID X 13"L	1	5-5013
Mount, Rubber 1" X 6mm	1	1228599
Washer, 6mm Soft Mount	1	559999
Nut, M6 Hex Serrated	1	444.460.04
1/2" Bnd. Hose Clamp,2.15-3.00"	2	9440
1/2" Bnd. Hose Clamp,2.31-3.25"	1	9444
Hose Clamp, 3/4"	2	4093-5
Hose Clamp, 1"	2	99024.032

Read and understand these instructions BEFORE attempting to install this product. Failure to follow installation instructions and not using the provided hardware may damage the intake tube, throttle body and engine.

The AEM® intake system is a performance product that can be used safely during mild weather conditions. During harsh and inclement weather conditions, you must return your vehicle to stock OEM air box and intake tract configuration. Failure to follow these instructions will void your warranty.

1. Preparing Vehicle

- a. Make sure vehicle is parked on level surface.
- b. Set parking brake.
- c. If engine has run in the past two hours, let it cool down.
- d. Disconnect negative battery terminal.
- e. Do not discard stock components after removal of the factory system.

2. Removal of stock system

- a. Remove the stock air box assembly and attaching hardware from inside the fender well.
- b. Disconnect the breather hose from the air inlet tube.
- c. **CAUTION: Ensure the engine is completely cool before removing the coolant hose, or hot coolant will escape from the cooling system and cause injury or damage. Be sure to capture any lost coolant in a clean container.**
Disconnect the water bypass hose from throttle body or the fast idle thermo valve, where equipped, located at the lower portion of the throttle body. Disconnect the opposite side of the water bypass hose, which runs to either the intake manifold or the water outlet neck. Remove the entire water bypass hose and breather hose assembly from the vehicle.
- d. Loosen and remove the air inlet tube from the throttle body.
- e. Raise the front of the vehicle with a jack. Refer to your owner's manual for proper jack and jack stand placement to properly support vehicle. Support your vehicle using properly rated jack stands before wheel removal or while working under the vehicle.
NEVER WORK UNDER A VEHICLE WITHOUT USING JACK STANDS.
 - i. Remove the lower front splashguard.
 - ii. Remove the front right wheel and remove the inner fender liner.
- f. Remove the resonator from underneath the vehicle.

3. Installation of AEM® intake system.

- a. When installing the intake system, do not completely tighten the hose clamps or mounting hardware until instructed to do so.
- b. Install one connector hose on the throttle body end of the inlet tube. That is the end closest to the breather nipple.
 - i. Install two hose clamps on the connector hose and snug them down on the hose.
- c. Attach the tube to the throttle body while slowly turning or twisting the tube so that it does not touch any surrounding component along its path.
 - i. If required, tighten the hose clamps slightly so that you can still rotate the tube during the remainder of the installation but will also prevent the tube from falling off.
- d. Insert this pipe through the hole left exposed by the removal of the resonator.
- e. Install the AEM® air filter onto the end of the inlet tube. Push the air filter on around 2 inches over the inlet pipe and install one hose clamp to secure the air filter onto the inlet pipe. Once fitment is checked, you can either push the air filter onto the inlet pipe more or less depending on clearances. Tighten the hose clamp

after this is done

- f. Check the placement of the air inlet tube for proper alignment. Make sure that the tube does not contact any component along its route nor should it interfere with the function of any other accessory.
 - i. Tighten the hose clamps on the throttle body.
- g. The support tab on the inlet pipe will line up with a threaded hole on the inner fender well. Install the rubber isolator mount and attach the air inlet tube onto the rubber mount. Install the large fender washer and the lock nut onto the isolator mount stud and snug it down.

NOTE: Failure to install the rubber mount will void all warranties of the AEM® intake system. Below is a diagram of how the rubber mount should be installed.

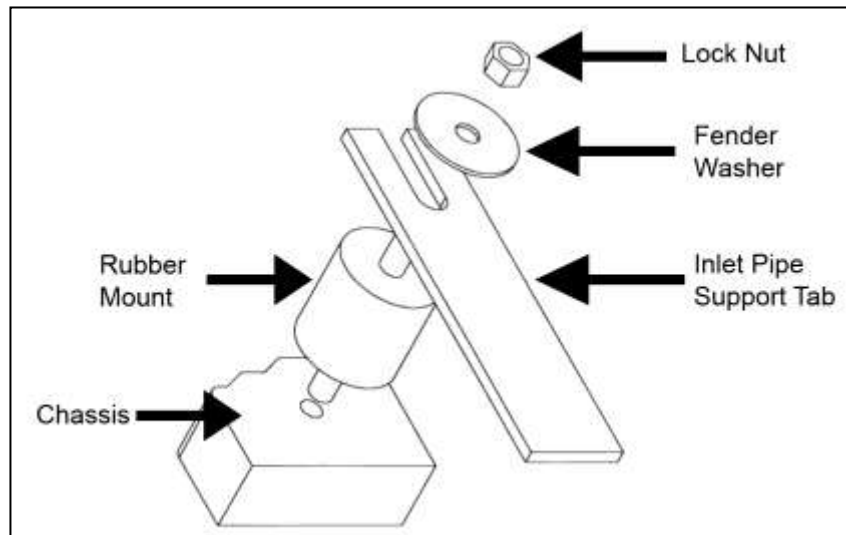

- h. Connect the breather hose to the inlet tube using the black breather hose and supplied hose clamps.
- i. Connect the new supplied water bypass hose and clamps to the throttle body or the fast idle thermo valve, where equipped, and either the intake manifold or the water outlet neck disconnected earlier.

NOTE: Replace any coolant recovered during hose removal by replenishing the recovery tank.

4. Reassemble Vehicle

- a. **Fender liner and splashguard:** Install the inner fender liner, lower splash guard and any hardware that was removed in steps 2ei and 2eii.
 - NOTE: Failure to install the fender liner will result in diminished performance and increase the potential for engine damage due to water ingestion in rainy conditions.**
- b. **Wheel:** Install the front right wheel using the factory torque specification (see owner's manual).
- c. Position the inlet pipes for the best fitment. Be sure that the pipes or any other components do not contact any part of the vehicle. Tighten the rubber mount, all bolts, and hose clamps.
- d. Check for proper hood clearance. Re-adjust pipes if necessary and re-tighten them.
- e. Inspect the engine bay for any loose tools and check that all fasteners that were moved or removed are properly tightened.
- f. Reconnect negative battery terminals and start engine. Let the vehicle idle for 3 minutes. Perform a final inspection before driving the vehicle.

5. CARB Sticker Placement

- a. The C.A.R.B. exemption sticker, (attached), must be visible under the hood so that an emissions inspector can see it when the vehicle is required to be tested for emissions. California requires testing every two years, other states may vary.

6. Service and Maintenance

- a. It is recommended that you service your AEM[®] Dryflow™ filter every 20,000 miles for optimum performance. Use AEM Dryflow cleaning kit part # 21-110.
- b. Use aluminum polish to clean your polished AEM[®] intake tube.
- c. Use window cleaner to clean your powder coated AEM[®] intake tube. **(NOTE: DO NOT USE aluminum polish on powder coated AEM intake tubes).**

For technical inquiries
e-mail us at
sales@aemintakes.com
or
call us at
800.992.3000

AEM Air Intake System Warranty Policy

AEM[®] warrants that its intake systems will last for the life of your vehicle. AEM will not honor this warranty due to mechanical damage (i.e. improper installation or fitment), damage from misuse, accidents or flying debris. AEM will not warrant its powder coating if the finish has been cleaned with a hydrocarbon-based solvent. The powder coating should only be cleaned with a mild soap and water solution. Proof of purchase of both the vehicle and AEM intake system is required for redemption of a warranty claim.

This warranty is limited to the repair or replacement of the AEM part. In no event shall this warranty exceed the original purchase price of the AEM part nor shall AEM be responsible for special, incidental or consequential damages or cost incurred due to the failure of this product. Warranty claims to AEM must be transportation prepaid and accompanied with dated proof of purchase. This warranty applies only to the original purchaser of product and is nontransferable. Improper use or installation, use for racing, accident, abuse, unauthorized repairs or alterations voids this warranty. AEM disclaims any liability for consequential damages due to breach of any written or implied warranty on all products manufactured by AEM. Warranty returns will only be accepted by AEM when accompanied by a valid Return Merchandise Authorization (RMA) number. Credit for defective products will be issued pending inspection. Product must be received by AEM within 30 days of the date RMA is issued.

If you have a warranty issue, please call (800) 992-3000 and our customer service department will assist you. A proof of purchase is required for all AEM warranty claims.