



Equipped with AEM® Dryflow™ Filter  
No Oil Required!

## INSTALLATION INSTRUCTIONS

### PART NUMBER: 21-499

---

2011	NISSAN	Altima	V6-3.5L	SEE * NOTE
2007-2010	NISSAN	Altima	V6-3.5L	C.A.R.B. E.O. # D-670-6

**\* NOTE: Legal in California only for racing vehicles which may never be used upon a highway**

## PARTS LIST

Description	Qty.	Part Number
A	1	21-203DK
B	1	2-4991
C	1	2-4992
D	1	20-499
E	1	5-357
F	1	8-4030
G	1	5-323
H	1	5-351
I	1	5-7021
J	1	784640
K	1	102504
L	2	1-127
M	2	2-670
N	1	7-7885
O	1	7-7886
P	2	1-2002
Q	3	1-2065
R	8	08160
S	4	444.460.04
T	2	08411
U	1	9448
V	2	9452
W	3	9456

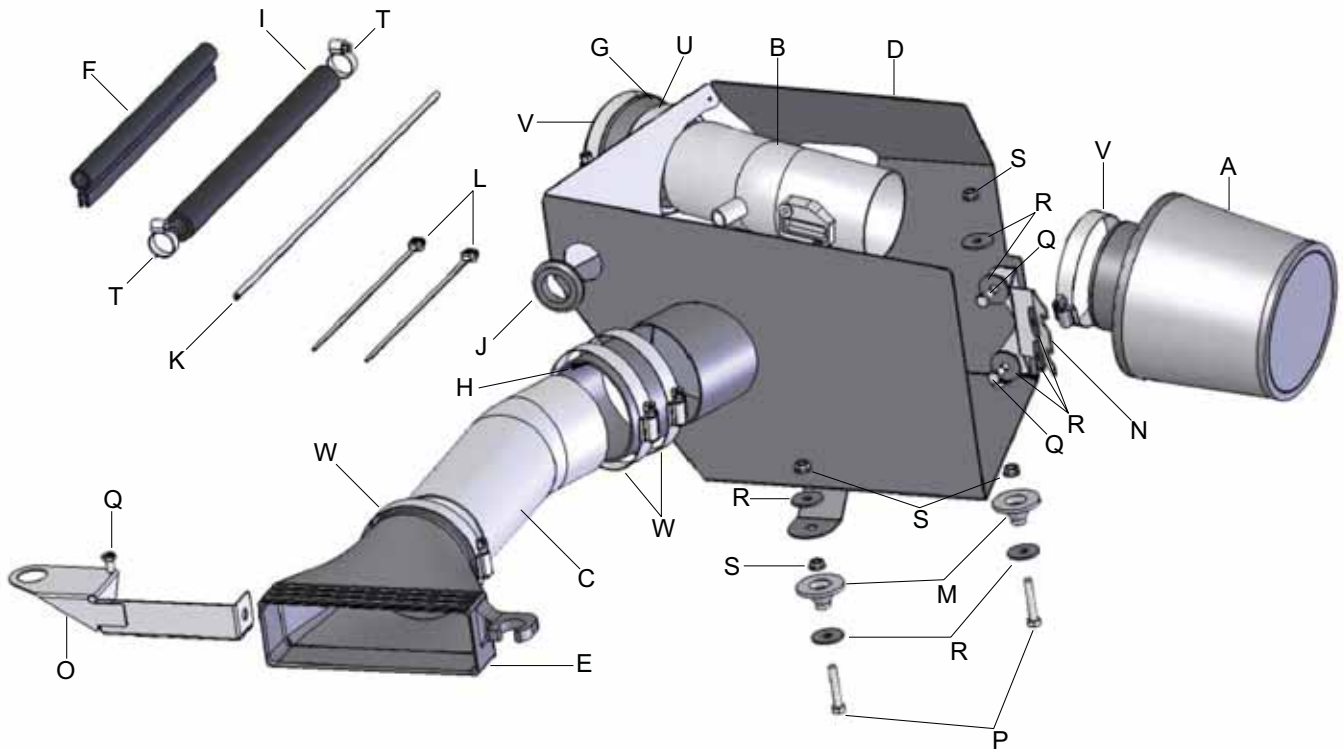

Read and understand these instructions **BEFORE** attempting to install this product. Failure to follow installation instructions and not using the provided hardware may damage the intake tube, throttle body and engine.

## 1. Preparing Vehicle

- a. Make sure vehicle is parked on level surface.
- b. Set parking brake.
- c. If engine has run in the past two hours, let it cool down.
- d. Do not discard stock components after removal of the factory system.

## 2. Removal of stock system



a. Open the hood and disconnect the negative battery cable.



b. Loosen and remove the socket cap head screws on the engine cover.



c. Loosen and remove the hex head screw on the trim cover.

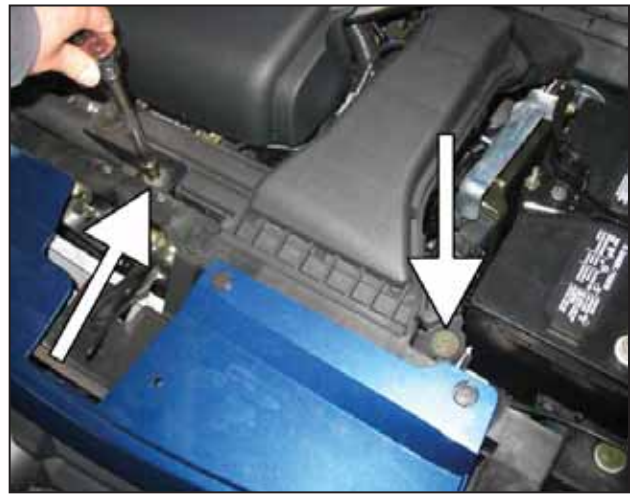

d. Loosen and remove the two hex head screws on the fresh air duct.



e. Remove the fresh air duct.



f. Remove the engine cover by pulling the cover upward at the front edge.



g. Loosen the clamp securing the positive crank case ventilation (PCV) resonator.



h. Remove the PCV resonator from the inlet duct.



i. Loosen the hose clamp securing the inlet duct to the throttle body.



j. Unplug the Mass Air Flow (MAF) sensor harness connector from the sensor.



k. Slide the PCV hose clamp off of the engine's PCV port.



l. Remove the PCV hose from the vehicle.



m. Unclip the two metal clips on the air box.



n. Remove the air box lid and the inlet duct.



o. Remove the MAF sensor harness clip from the back of the air box lid.

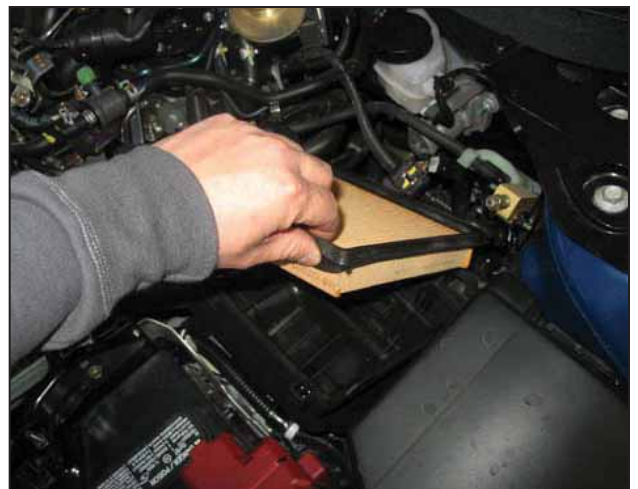

p. Remove the air filter.



q. Remove the hex head screw securing the air box base.



r. Remove the air box base by lifting upwards, this will require some effort because the base is secured in place with two rubber grommets on the bottom side.



s. Remove the clip securing the rubber tube.

### 3. Installation of AEM® intake system.

a. When installing the intake system, do not completely tighten the hose clamps or mounting hardware until instructed to do so.



b. Prepare two M6-1 x 35mm bolts with two M6 fender washers as shown.



c. The hardware prepared in step 3b will slide through the factory grommets as shown. If the factory grommets are missing, check the bottom of the air box base or the engine bay as they may have fallen out when the air box was removed.



d. Install the cone shaped aluminum stand in the grommet. Secure the hardware from step 3c with a M6 serrated nut.



e. Repeat the procedure in step 3d for the other grommet located by the battery.



f. Ensure that the hardware securing the aluminum stands is completely tightened.



g. Install the 3.25" to 3.00" diameter hose adapter onto the throttle body. Secure the adapter in place with a #9452 hose clamp. Slide a #9448 hose clamp onto the smaller diameter side of the adapter hose.

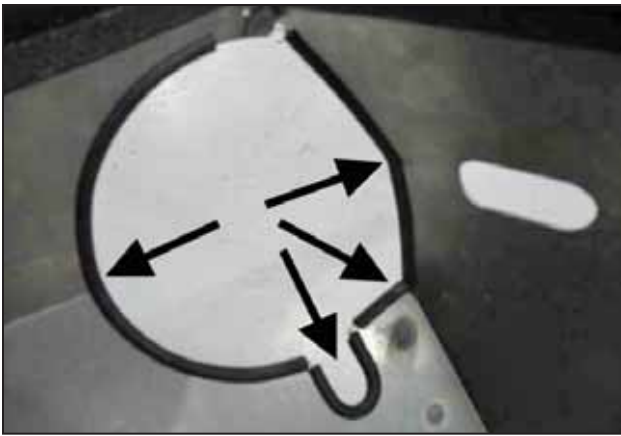

h. Line the edges on the heat shield with the supplied rubber edge trim.



i. Install the edge trim onto the top edges of the heat shield and trim to fit. Install the rubber grommet in the heat shield hole as shown.



j. Install the heat shield in the vehicle, aligning the holes of the heat shield base with the aluminum mounts that were installed in steps 3d-3f.



k. With the heat shield in place, install M6 fender washers and M6 nuts over each mounting stud. The black box mounted to the firewall near the heat shield may need to be adjusted for clearance. Carefully bend the black box's bracket towards the firewall to allow enough clearance.



l. Remove the two nuts from the circled studs on the shock tower. Install the rear bracket as shown, use two M6 fender washers and M6-1 x 12mm hex head bolts to secure the bracket to the heat shield. Do not completely tighten the bolts.



m. Place two M6 fender washers over the two shock tower studs. Reinstall the two nuts that were removed in the previous step. Completely tighten the two bolts and two nuts securing the bracket.

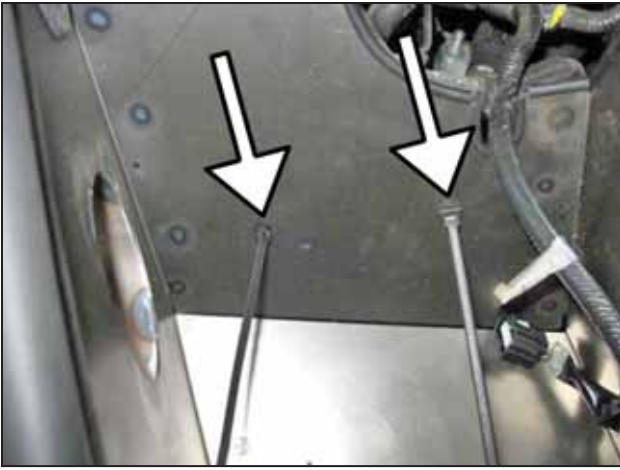

n. Install two push in zip ties on the inside wall of the heat shield. Route the MAF sensor wiring into the heat shield as shown.



o. Cut the factory zip tie securing the wiring harness to the plastic push-in mounting tab.



p. Route the MAF sensor wiring as shown and secure the wiring harness with the two zip ties. Trim the excess zip tie ends.



q. Remove the MAF sensor from the factory air box lid. Install the MAF sensor into the intake pipe with the factory screws. Install the air filter onto the intake pipe and secure it with a #9452 hose clamp.



r. Install the intake pipe assembly as shown. Position for optimal clearance, ensuring that the assembly does not contact any surrounding parts. Secure the intake pipe to the coupler installed on the throttle body.



s. Plug in the MAF sensor harness connector to the MAF sensor



t. Insert the 5/8" I.D. PCV hose through the heat shield grommet and connect it to the intake pipe's nipple. Secure the PCV hose with a 1 1/16" hose clamp.



u. Connect the other end of the PCV hose to the port on the engine. Secure the PCV hose with a 1-1/16" hose clamp.



v. Install the 3.50" x 2" silicone coupler onto the heat shield inlet tube. Slide two #9456 hose clamps onto the silicone coupler.



w. Remove the rubber grommet on the factory fresh air duct.



x. Install the rubber grommet onto the bracket as shown.



y. Remove the metal sleeve and rubber grommet from the factory fresh air duct.



z. Install the rubber grommet and metal sleeve into the air inlet scoop as shown.



ab. Secure the air supply duct to the air supply scoop with a #9456 hose clamp. Install the assembly as shown.



ad. Secure the air supply scoop with the factory hex head bolt.

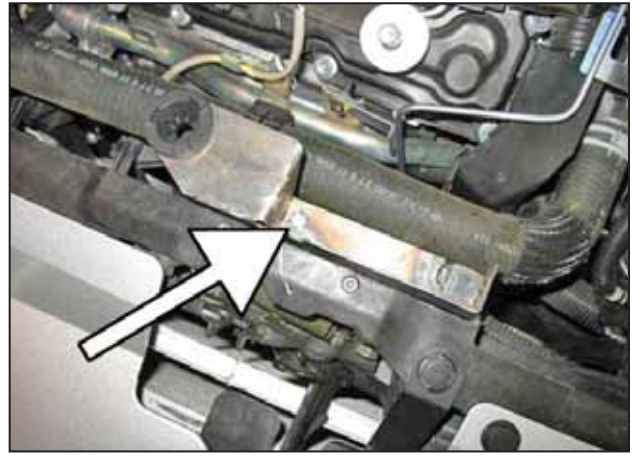

aa. Install the bracket with a M6-1x 12mm hex head bolt. Tighten the bolt enough to hold the bracket in place, but do not completely tighten.



ac. Insert the nub of the air supply scoop into the hole of the bracket.

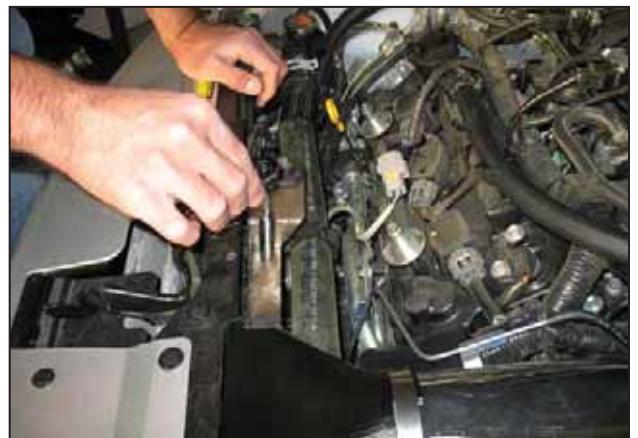

ae. Tighten the M6 hex head bolt securing the bracket.



af. Install the factory plastic radiator trim as shown.



ag. Using the factory hex head bolt, secure the radiator trim panel in place.



ah. Install the engine cover that was removed.



ai. Secure the engine cover with the hardware removed in step 2b.



Factory air box system installed



AEM® intake system installed

#### 4. Reassemble Vehicle

- a. Position the inlet pipes for the best fitment. Be sure that the pipes or any other components do not contact any part of the vehicle. Tighten the rubber mount, all bolts, and hose clamps.
- b. Check for proper hood clearance. Re-adjust pipes if necessary and re-tighten them.
- c. Inspect the engine bay for any loose tools and check that all fasteners that were moved or removed are properly tightened.
- d. Reconnect negative battery terminal and start engine. Let the vehicle idle for 3 minutes. Perform a final inspection before driving the vehicle.

#### 5. CARB Sticker Placement

- a. The C.A.R.B. exemption sticker, (attached), must be visible under the hood so that an emissions inspector can see it when the vehicle is required to be tested for emissions. California requires testing every two years, other states may vary.

#### 6. Service and Maintenance

- a. AEM Induction Systems requires cleaning the intake system's air filter element every 100,000 miles. When used in dusty or off-road environments, our filters will require cleaning more often. We recommend that you visually inspect your filter once every 25,000 miles to determine if the screen is still visible. When the screen is no longer visible some place on the filter element, it is time to clean it. To clean, purchase our Synthetic air filter cleaner, part number 99-0624 and follow the easy instructions.

- b. Use window cleaner to clean your powder coated AEM® intake tube.

**NOTE: DO NOT USE aluminum polish on powder coated AEM® intake tubes.**

For technical inquiries e-mail us at sales@aemintakes.com or call us at 800.992.3000
---

#### AEM Air Intake System Warranty Policy

AEM® warrants that its intake systems will last for the life of your vehicle. AEM will not honor this warranty due to mechanical damage (i.e. improper installation or fitment), damage from misuse, accidents or flying debris. AEM will not warrant its powder coating if the finish has been cleaned with a hydrocarbon-based solvent. The powder coating should only be cleaned with a mild soap and water solution. Proof of purchase of both the vehicle and AEM intake system is required for redemption of a warranty claim.

This warranty is limited to the repair or replacement of the AEM part. In no event shall this warranty exceed the original purchase price of the AEM part nor shall AEM be responsible for special, incidental or consequential damages or cost incurred due to the failure of this product. Warranty claims to AEM must be transportation prepaid and accompanied with dated proof of purchase. This warranty applies only to the original purchaser of product and is nontransferable. Improper use or installation, use for racing, accident, abuse, unauthorized repairs or alterations voids this warranty. AEM disclaims any liability for consequential damages due to breach of any written or implied warranty on all products manufactured by AEM. Warranty returns will only be accepted by AEM when accompanied by a valid Return Merchandise Authorization (RMA) number. Credit for defective products will be issued pending inspection. Product must be received by AEM within 30 days of the date RMA is issued.

If you have a warranty issue, please call (800) 992-3000 and our customer service department will assist you. A proof of purchase is required for all AEM warranty claims.