



Equipped with AEM® Dryflow™ Filter  
No Oil Required!

## INSTALLATION INSTRUCTIONS

### PART NUMBER: 41-1406

---

2006-2010 LEXUS IS250 V6-2.5L SEE \* NOTE

\* NOTE: Legal in California only for racing vehicles which may never be used upon a highway

## PARTS LIST

	Description	Qty.	Part Number
A	Inlet Pipe	1	2-1477
B	Hose, Silicone 3.00x3" Blk.	1	5-300
C	1/2" Bend Hose Clamp, 2.56"-3.50"	2	9448
D	Bolt, Btn. Hd. M4-0.7 X 6mm	2	1-2051
E	Bolt, Hex, M8-1.25 X 25mm	1	1-2066
F	Washer, 8mm Soft Mount	1	559960
G	Air Filter, 3.00"X5" Dryflow	1	21-203DK
H	1/2" Bend. Hose Clamp, 2.90"-3.75"	1	9452
I	Heat Shield; Lexus Is 06-08, TB/PC	1	20-14021
J	Bolt, Hex/Flange M6-1 X 20	1	1-2038
K	Edge Trim 34"	1	8-4034
L	ETI Module, Lexus IS250, Programmed	1	40-1406-002
M	Plug, Lg. Tree Clip Blk.	2	8-166
N	Rubber Edge Trim 5"	1	8-3005
O	Edge Trim; 3/4" Bulb, Side Loc, 5"L	1	8-4105

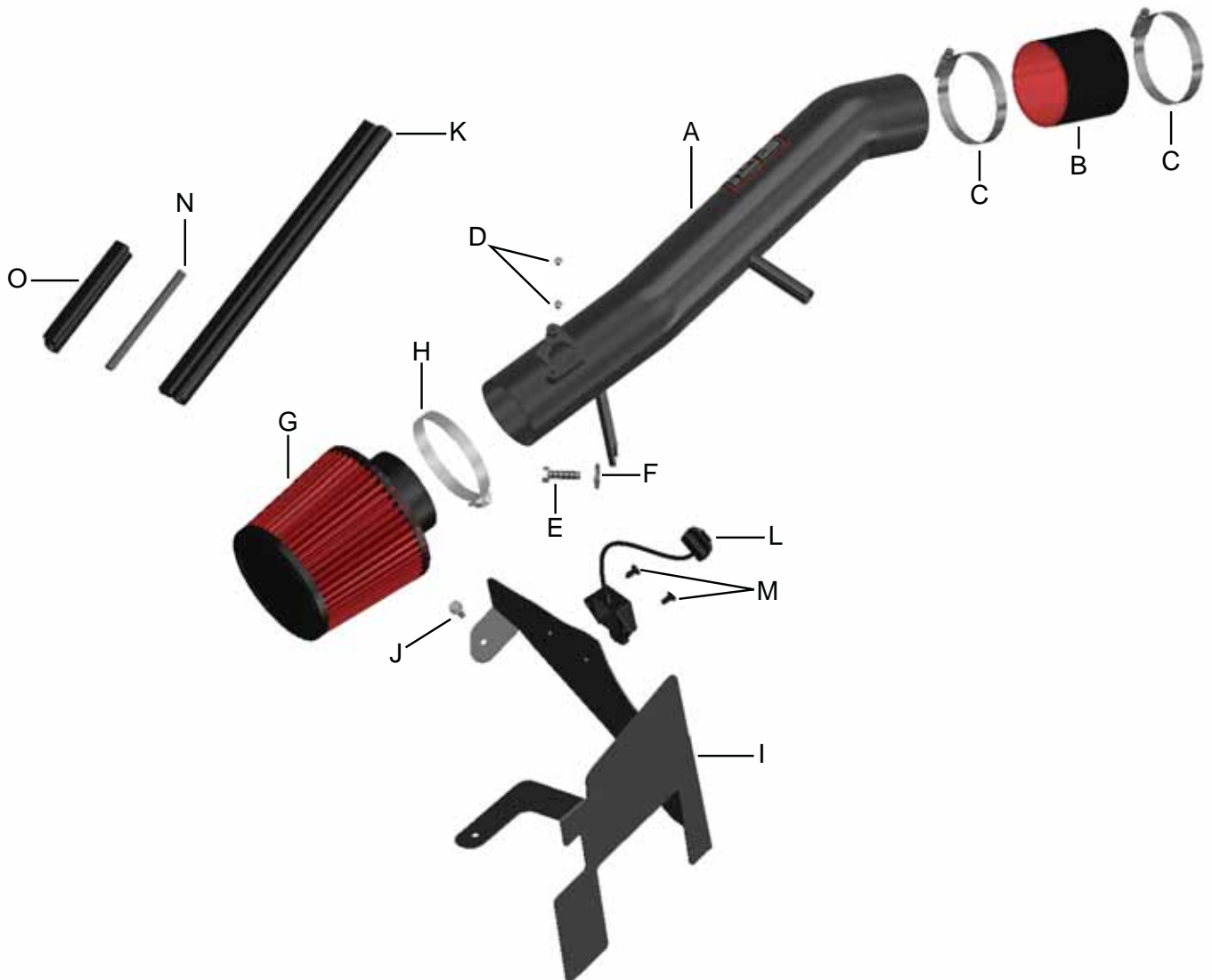

Read and understand these instructions **BEFORE** attempting to install this product. Failure to follow installation instructions and not using the provided hardware may damage the intake tube, throttle body and engine.

The AEM® intake system is a performance product that can be used safely during mild weather conditions. During harsh and inclement weather conditions, you must return your vehicle to stock OEM airbox and intake tract configuration. Failure to follow these instructions will void your warranty.

## 1. Preparing Vehicle

- a. Make sure vehicle is parked on level surface.
- b. Set parking brake.
- c. If engine has run in the past two hours, let it cool down.
- d. Do not discard stock components after removal of the factory system.

## 2. Removal of stock system



a. Factory airbox system installed.



b. Disconnect the negative battery terminal.



c. Remove the engine cover.



d. Remove the 11 plastic clips to remove the front panel cover.

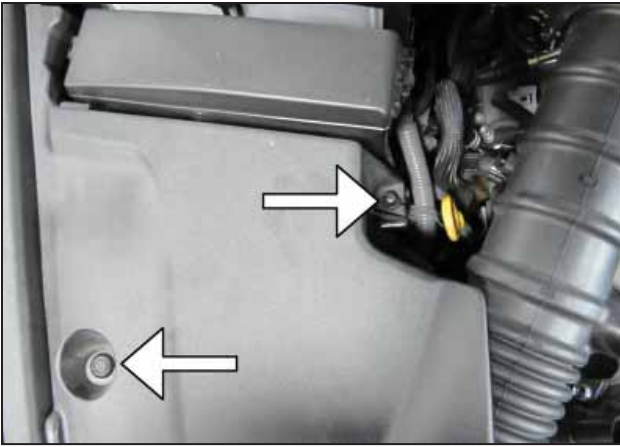

e. Loosen the (1) plastic screw and (1) plastic clip to remove the engine side bay cover.



f. To remove the front inlet duct, remove the (1) plastic clip and (1) bolt securing the duct in place. Slide the scoop out of the airbox and set aside.

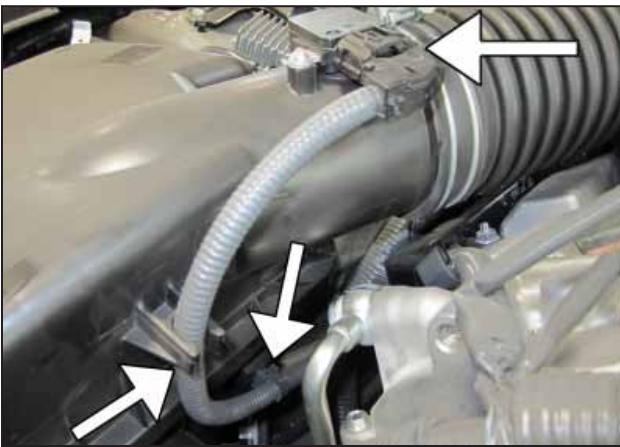

g. Unplug the harness from the MAF sensor and unclip from the upper and lower airbox as shown.



h. Unhook the (4) airbox clips.



i. Disconnect the breather hose on the inlet tube.



j. On the bottom of the inlet tube, disconnect the plastic clip from the hose.



k. Loosen the hose clamp securing the inlet tube to the throttle body and carefully slide off the inlet tube.



l. Remove the two M10 bolts securing the lower air box. Remove and set aside.

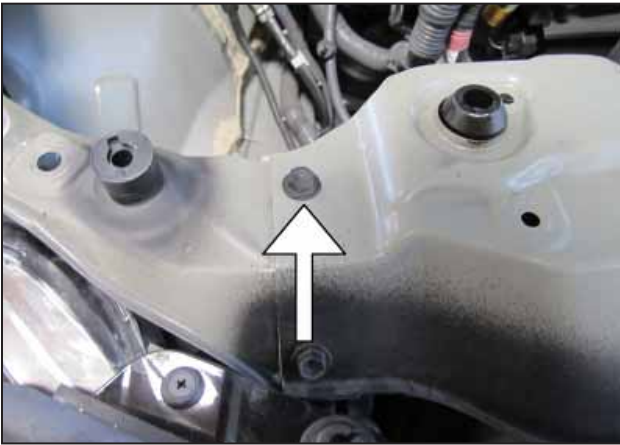

m. Remove the M10 bolt from the front support.  
**NOTE: This bolt will be reused during the AEM® intake installation.**



n. Using a Phillips screwdriver, remove the MAF sensor from the stock inlet tube.

### 3. Installation of AEM® Intake System

a. When installing the intake system, do not completely tighten the hose clamps or mounting hardware until instructed to do so.



b. Mount the ETI module to the heat shield as shown using the (2) provided plastic tree clips (8-166).



c. Install edge trim 8-3005 and 8-4105 onto the heat shield as shown.



d. Cut edge trim (8-4034) and fit along the heat shield edges as shown. Trim accordingly to ensure proper fitment.

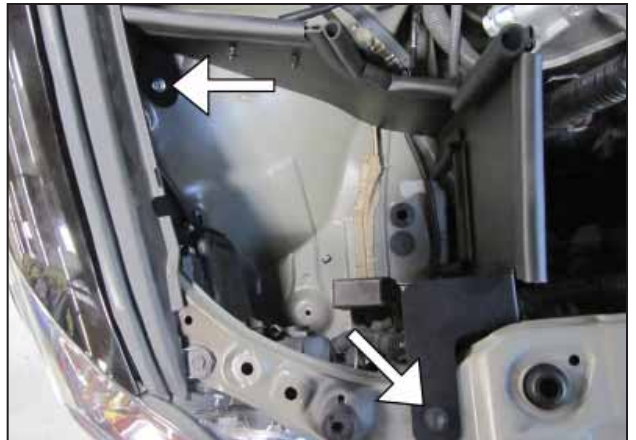

e. Install the heat shield, using bolt (1-2038) to fasten the heat shield to the inner fender. Secure the front heat shield support to the radiator support with the stock bolt (Removed in step 2m).



f. Connect the wire harness to the ETI module.

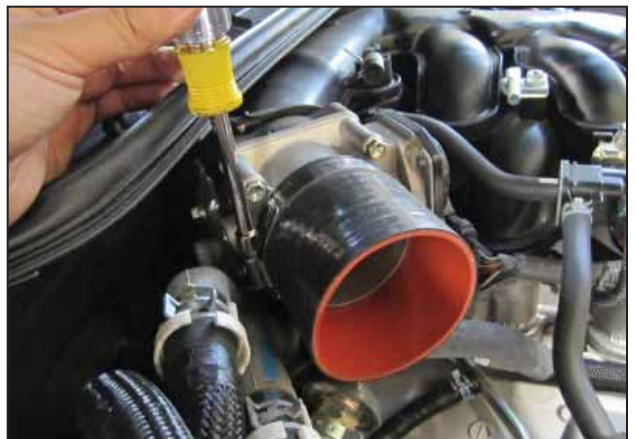

g. Fasten silicone coupler (5-300) to the throttle body using hose clamp (9448).



h. Loosely install M8 bolt (1-2066) and washer (559960) into the designated threaded hole located on the engine block.



i. Mount the MAF sensor onto the AEM® intake pipe using the provided M4 button head bolts (1-2051).



j. Slide the AEM® air filter over the inlet end of the intake pipe and fasten with the provided hose clamp (9452).



k. Loosen hose clamp (9448) and slide over the coupler installed on the throttle body inlet. Insert the AEM® intake pipe into the coupler and align the bracket to slide in-between the washer and engine block. Tighten the M8 bolt (1-2066), that was installed in step '3h' and tighten the hose clamp (9448) securing the intake tube to the throttle body.



l. Reinstall the stock air scoop into the heat shield and fasten down with the stock clip and bolt. Plug the ETI module into the MAF sensor. Connect the breather hose to the intake nipple and secure with the stock spring clamp.



m. Reinstall the rubber engine cover, ensuring adequate clearance between the intake tube and cover. Adjust if necessary. Reinstall front and side plastic panels. Reconnect the negative battery terminal.

#### 4. Reassemble Vehicle

- a. Position the inlet pipes for the best fitment. Be sure that the pipes or any other components do not contact any part of the vehicle. Tighten the rubber mount, all bolts, and hose clamps.
- b. Check for proper hood clearance. Re-adjust pipes if necessary and re-tighten them.
- c. Inspect the engine bay for any loose tools and check that all fasteners that were moved or removed are properly tightened.
- d. Reconnect the negative battery terminal and start the engine. Let the vehicle idle for 3 minutes. Perform a final inspection before driving the vehicle.

#### 5. Service and Maintenance

- a. It is recommended that you service your AEM® Dryflow™ filter every 20,000 miles for optimum performance. Use AEM Dryflow cleaning kit part # 21-110.
- b. Use aluminum polish to clean your polished AEM® intake tube.
- c. Use window cleaner to clean your powder coated AEM® intake tube. **(NOTE: DO NOT USE aluminum polish on powder coated AEM intake tubes).**

For technical inquiries  
e-mail us at  
sales@aemintakes.com  
or  
call us at  
800.992.3000

### **AEM Air Intake System Warranty Policy**

AEM® warrants that its intake systems will last for the life of your vehicle. AEM will not honor this warranty due to mechanical damage (i.e. improper installation or fitment), damage from misuse, accidents or flying debris. AEM will not warrant its powder coating if the finish has been cleaned with a hydrocarbon-based solvent. The powder coating should only be cleaned with a mild soap and water solution. Proof of purchase of both the vehicle and AEM intake system is required for redemption of a warranty claim.

This warranty is limited to the repair or replacement of the AEM part. In no event shall this warranty exceed the original purchase price of the AEM part nor shall AEM be responsible for special, incidental or consequential damages or cost incurred due to the failure of this product. Warranty claims to AEM must be transportation prepaid and accompanied with dated proof of purchase. This warranty applies only to the original purchaser of product and is nontransferable. Improper use or installation, use for racing, accident, abuse, unauthorized repairs or alterations voids this warranty. AEM disclaims any liability for consequential damages due to breach of any written or implied warranty on all products manufactured by AEM. Warranty returns will only be accepted by AEM when accompanied by a valid Return Merchandise Authorization (RMA) number. Credit for defective products will be issued pending inspection. Product must be received by AEM within 30 days of the date RMA is issued.

If you have a warranty issue, please call (800) 992-3000 and our customer service department will assist you. A proof of purchase is required for all AEM warranty claims.