



Equipped with AEM® Dryflow™ Filter
No Oil Required!

INSTALLATION INSTRUCTIONS

PART NUMBER: 24-6104

2004 – 2005 HONDA S2000 L4-2.2L
2000 – 2003 HONDA S2000 L4-2.0L

C.A.R.B. E.O. # D-670
C.A.R.B. E.O. # D-670

* **NOTE:** Legal in California only for racing vehicles which may never be used upon a highway

PARTS LIST

Description	Qty.	Part Number
Air Filter Assy. 3.50 X 5" Dry Ele.	1	21-204DK
Upper Pipe	1	2-61041
Lower Pipe	1	2-61042
Hose; 5/16ID X 12"L	1	5-2012
Hose, Silicone 2.75x3" Blk.	2	5-275
Hose; 1/2"ID X 12"L	1	5-5012
Hose; 5/32"ID X 15"L	2	5-3015
Mount, Rubber 1" X 6mm	1	1228599
Zip Tie, 11.25 Long	2	1-115
Drain Valve, 0.500"	1	8-145
Washer, 6mm Soft Mount	2	559999
Nut, M6 Hex Serrated	2	444.460.04
1/2" Bnd. Hose Clamp, 2.31-3.25"	4	9444
Hose Clamp, 1"	2	99024.032
1/2" Bnd. Hose Clamp, 3.15"-4.00"	1	9456

Read and understand these instructions **BEFORE** attempting to install this product. Failure to follow installation instructions and not using the provided hardware may damage the intake tube, throttle body and engine.

1. Preparing Vehicle

- a. Make sure vehicle is parked on level surface.
- b. Set parking brake.
- c. If engine has run in the past two hours, let it cool down.
- d. Disconnect negative battery terminal.
- e. Raise the front of the vehicle with a jack. Refer to your owner's manual for proper jack and jack stand placement to properly support vehicle. Support your vehicle using properly rated jack stands before wheel removal or while working under the vehicle.

NEVER WORK UNDER A VEHICLE WITHOUT USING JACK STANDS.

- f. Do not discard stock components after removal of the factory system.

2. Removal of stock system

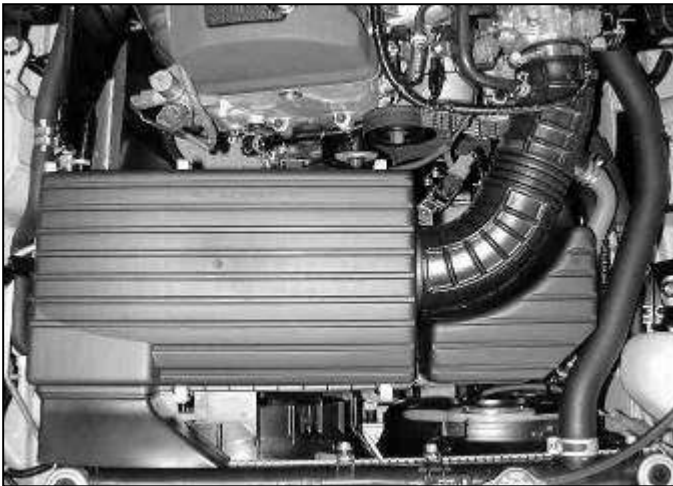

a. Make note of the locations of the O.E. components. There is one breather hose, one vacuum hose, and one air control solenoid.

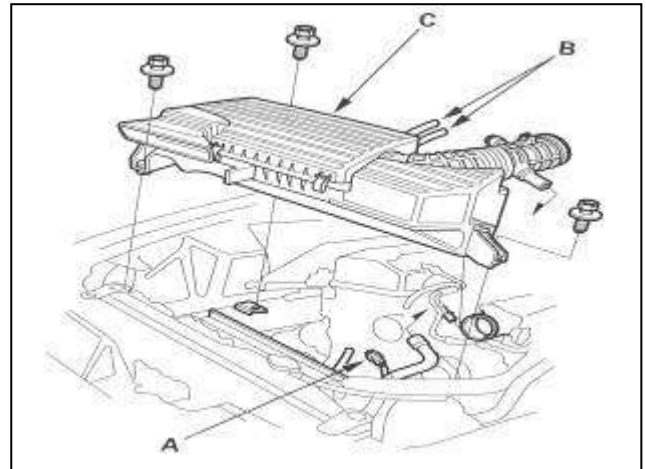

b. Disconnect the air control solenoid valve connector (A), and then remove the vacuum hoses (B).

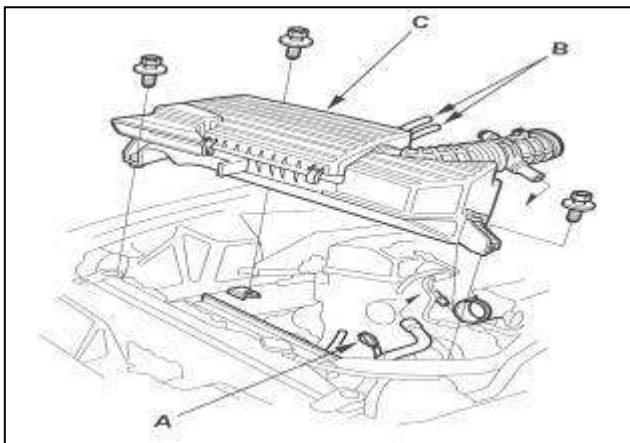

c. Loosen the throttle body hose clamp, loosen the three mounting bolts, and remove the air cleaner housing/intake duct (C) assembly.

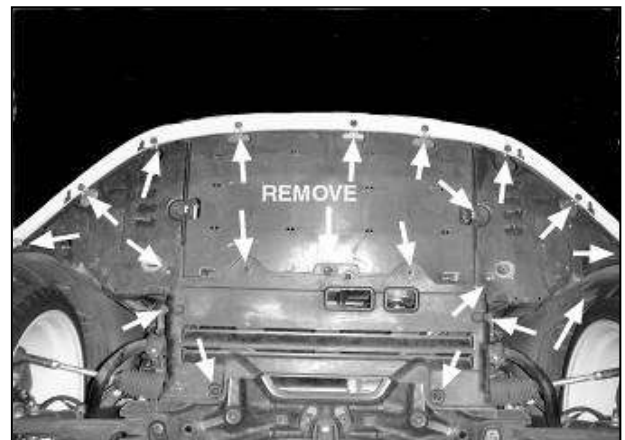

d. Remove the front passenger side wheel. Remove the plastic under trays, and loosen the passenger side inner fender liner as shown.

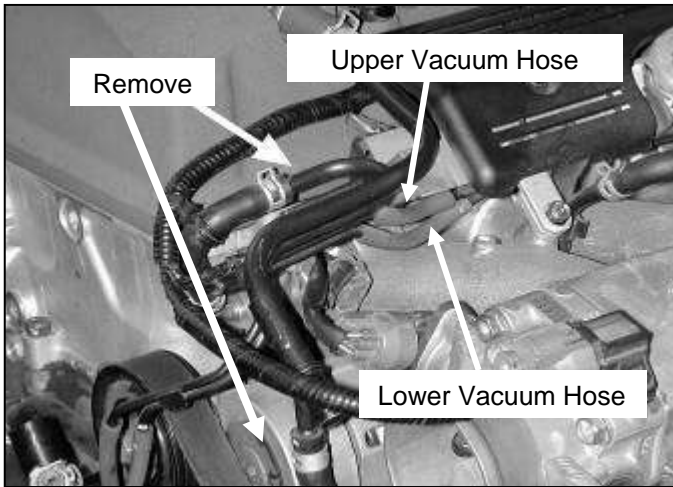

e. CAUTION: Ensure the engine is completely cool before removing the coolant hose, or hot coolant will escape from the cooling system and cause injury or damage. Be sure to capture any lost coolant in a clean container.

Remove the metal tubing loom, which will include the breather hose, coolant hose and air control solenoid valve vacuum hoses. Make sure to note proper hose routing. (Place a rag under the loom, as coolant will leak from the lower hose).

3. Installation of AEM® intake system.

a. When installing the intake system, do not completely tighten the hose clamps or mounting hardware until instructed to do so.

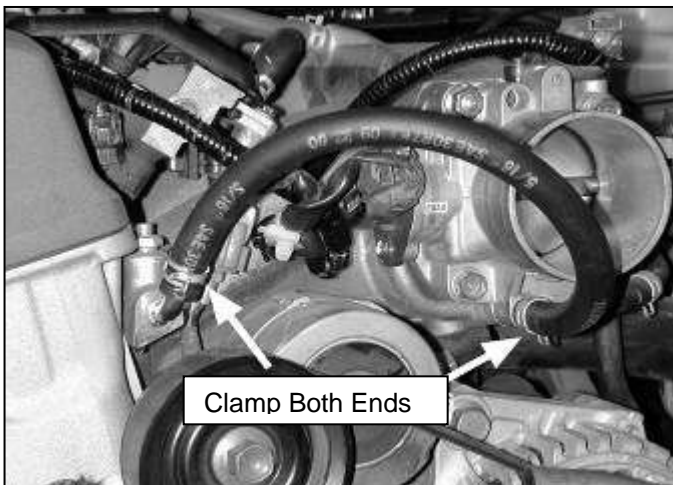

b. Install the provided 5/16" hose between the throttle body and the bleeder outlet vacated by the removal of lower hose of the metal tube loom. Use the factory hose clamps as shown.

NOTE: Replace any coolant recovered during hose removal by replenishing the recovery tank.

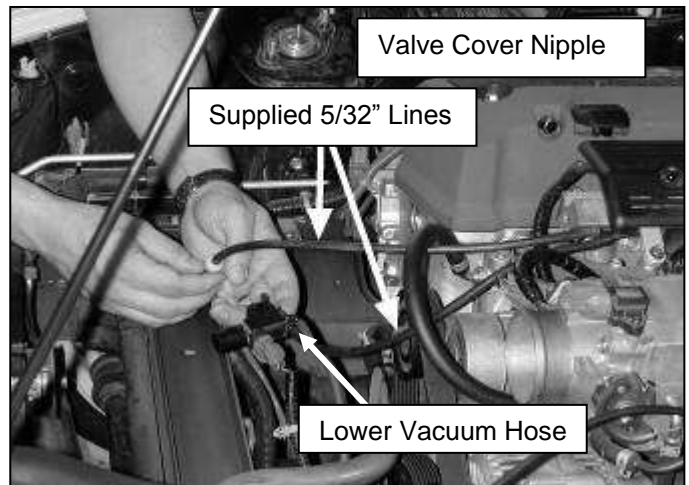

c. Replace the factory air control solenoid valve vacuum lines with the supplied 5/32" lines, as shown. Use the two supplied zip ties to zip tie the hoses away from the serpentine belt. Install the supplied breather hose onto the valve cover nipple using the supplied #44 hose clamps.



d. Install the 2.75" hose on to the throttle body using the #44 hose clamps. Check to see that the inside of the AEM® inlet pipe and air filter are clean and free from any foreign objects and/or obstructions.

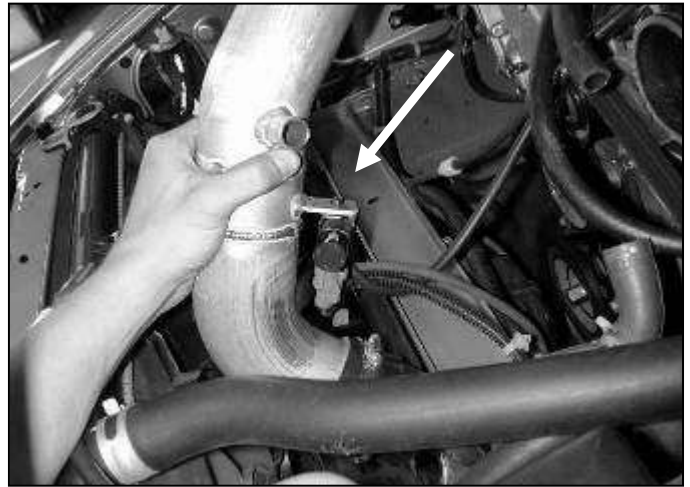

e. Using the factory bolt, secure the air control solenoid valve to the bracket on the upper cold air pipe as shown.

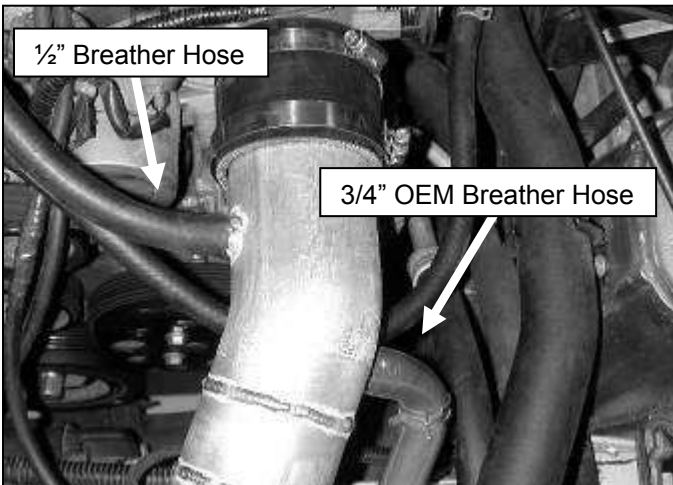

f. Install the upper Intake pipe by inserting the end with the smaller nipple into the 2.75" hose on the throttle body. Attach the 1/2" breather hose and the 3/4" breather hose as shown. Use the factory hose clamp on the 3/4" hose and the supplied hose clamp on the 1/2" hose.



g. Install the supplied rubber mount into the passenger side radiator support frame rail as shown. When tightening the nut, tighten until the thin outer wall of the support starts to deflect (See next picture g. for closer view).

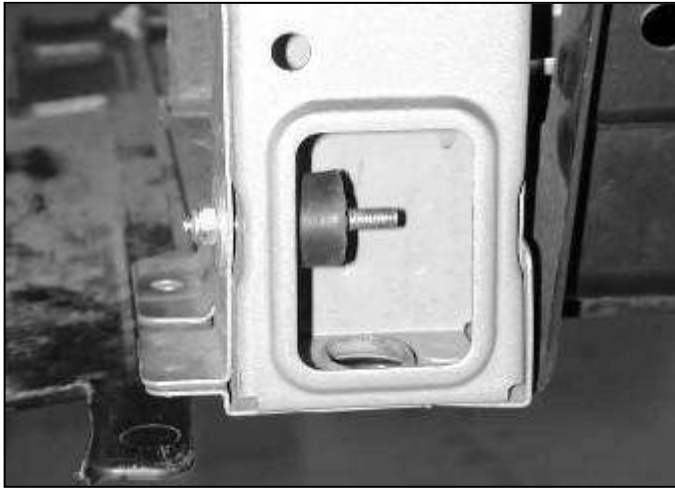

h. Install the supplied rubber mount into the passenger side radiator support frame rail as shown. When tightening the nut, tighten until the thin outer wall of the support starts to deflect.

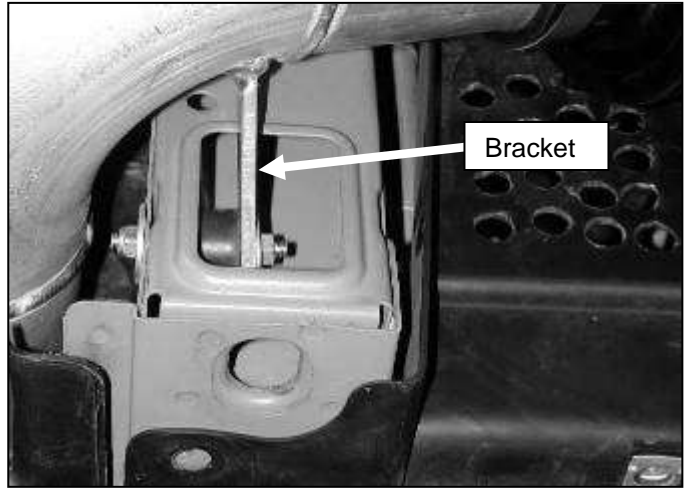

i. Install the lower intake pipe behind the radiator with the bracket sliding onto the rubber mount. Use the washer and screw on the nylok nut but do not tighten at this time.

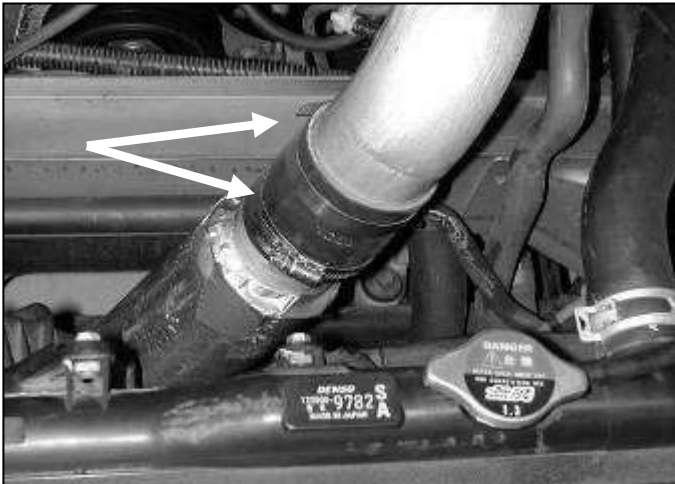

j. Using the 2.75" silicone hose and two hose clamps supplied, attach the upper and lower intake pipes together.

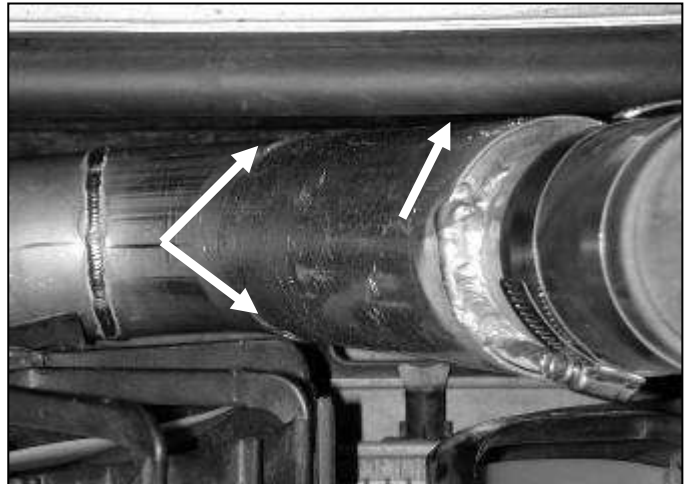

k. Check the lower intake pipe clearance between the radiator fan guard, the A/C line, and the sway bar.

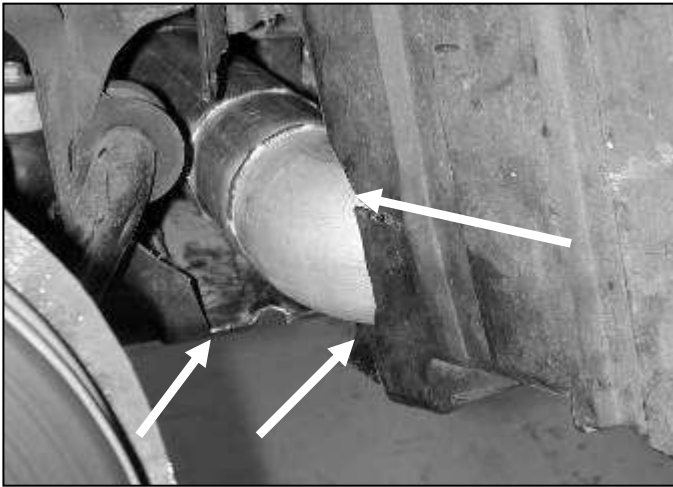

l. Trim the inner fender liner and under tray as shown for proper fit.

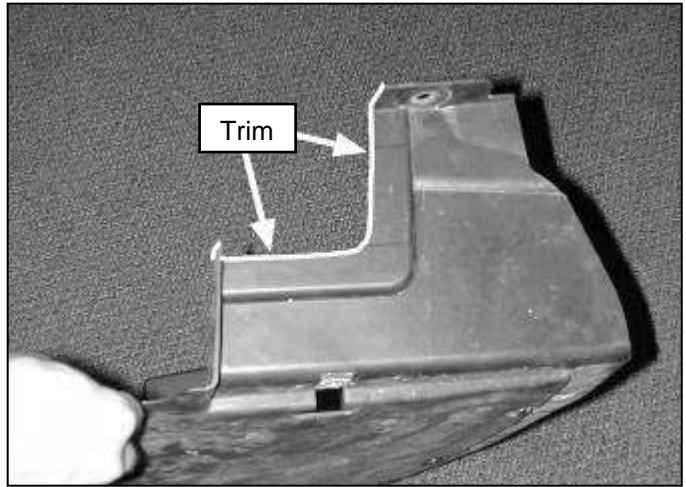

m. Trim the passenger's side under tray as shown. Reinstall the under trays, trimming or notching them for tube clearance where required.

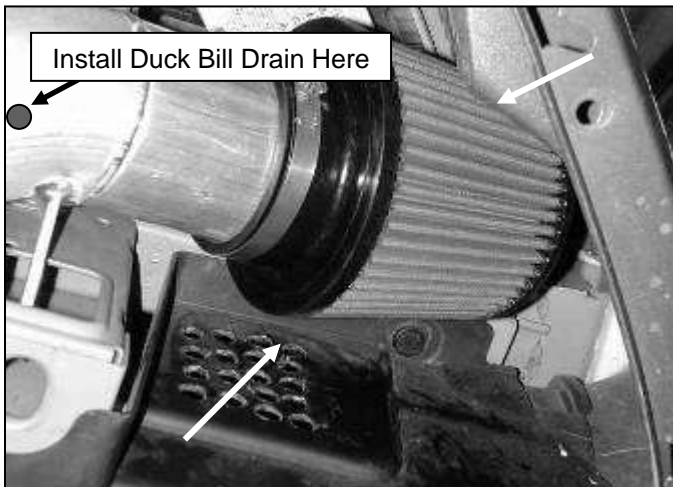

n. Install the AEM® air filter on to the end of the inlet tube. Push the air filter over the inlet pipe until the stop in the air filter is reached. Then install the #56 hose clamp to secure the filter onto the inlet pipe. Once fitment is checked, tighten the hose clamp. Install the duck bill drain into the 1/2" hole in the pipe.



o. Ensure the air filter is not touching any part of the vehicle. Position the inlet pipe for best fitment. Be sure that the pipe or any other component is not in contact with any part of the vehicle. Tighten the hose clamps at the throttle body and silicone coupling. Tighten the nut on the mounting bracket. Check for proper hood clearance. Re-adjust pipe if necessary.

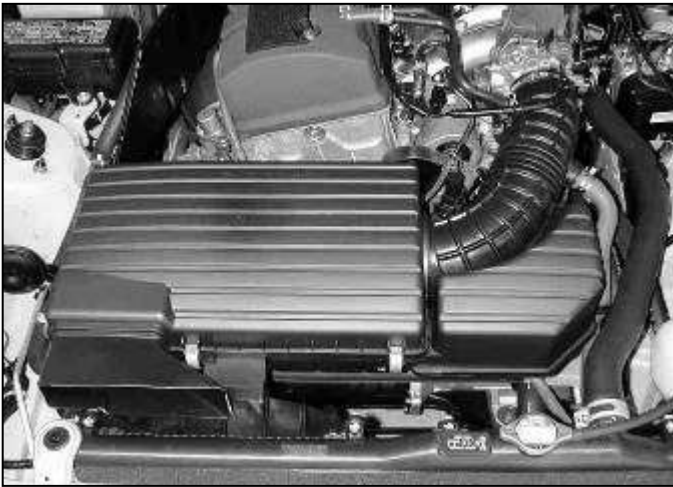

Factory air box system



AEM® intake system installed

4. Reassemble Vehicle

- a. **Wheel:** Install the passenger side wheel using the factory torque specification (see owner's manual).
- b. Position the inlet pipes for the best fitment. Be sure that the pipes or any other components do not contact any part of the vehicle. Tighten the rubber mount, all bolts, and hose clamps.
- c. Check for proper hood clearance. Re-adjust pipes if necessary and re-tighten them.
- d. Inspect the engine bay for any loose tools and check that all fasteners that were moved or removed are properly tightened.
- e. Reconnect negative battery terminals and start engine. Let the vehicle idle for 3 minutes. Perform a final inspection before driving the vehicle.

5. CARB Sticker Placement

- a. The C.A.R.B. exemption sticker, (attached), must be visible under the hood so that an emissions inspector can see it when the vehicle is required to be tested for emissions. California requires testing every two years, other states may vary.

6. Service and Maintenance

- a. It is recommended that you service your AEM® Dryflow™ filter every 20,000 miles for optimum performance. Use AEM Dryflow cleaning kit part # 21-110.
- b. Use aluminum polish to clean your polished AEM® intake tube.
- c. Use window cleaner to clean your powder coated AEM® intake tube. **(NOTE: DO NOT USE aluminum polish on powder coated AEM intake tubes)**

For technical inquiries
e-mail us at
sales@aemintakes.com
or
call us at
800.992.3000

AEM Air Intake System Warranty Policy

AEM® warrants that its intake systems will last for the life of your vehicle. AEM will not honor this warranty due to mechanical damage (i.e. improper installation or fitment), damage from misuse, accidents or flying debris. AEM will not warrant its powder coating if the finish has been cleaned with a hydrocarbon-based solvent. The powder coating should only be cleaned with a mild soap and water solution. Proof of purchase of both the vehicle and AEM intake system is required for redemption of a warranty claim.

This warranty is limited to the repair or replacement of the AEM part. In no event shall this warranty exceed the original purchase price of the AEM part nor shall AEM be responsible for special, incidental or consequential damages or cost incurred due to the failure of this product. Warranty claims to AEM must be transportation prepaid and accompanied with dated proof of purchase. This warranty applies only to the original purchaser of product and is nontransferable. Improper use or installation, use for racing, accident, abuse, unauthorized repairs or alterations voids this warranty. AEM disclaims any liability for consequential damages due to breach of any written or implied warranty on all products manufactured by AEM. Warranty returns will only be accepted by AEM when accompanied by a valid Return Merchandise Authorization (RMA) number. Credit for defective products will be issued pending inspection. Product must be received by AEM within 30 days of the date RMA is issued.

If you have a warranty issue, please call (800) 992-3000 and our customer service department will assist you. A proof of purchase is required for all AEM warranty claims.